

BUS 2-DRAADS
Bij monteren/demonteren **spanning eraf** voorkomt defecten!

SUI
De aders moeten **echt OP de klemmen** doorgelust worden!

≡ = systeemkabel
Bij andere getwiste kabel **66% afstand!**
Bij ongetwiste kabel **max. 50 meter** buitenpost naar videofoon. UTP op aanvraag.

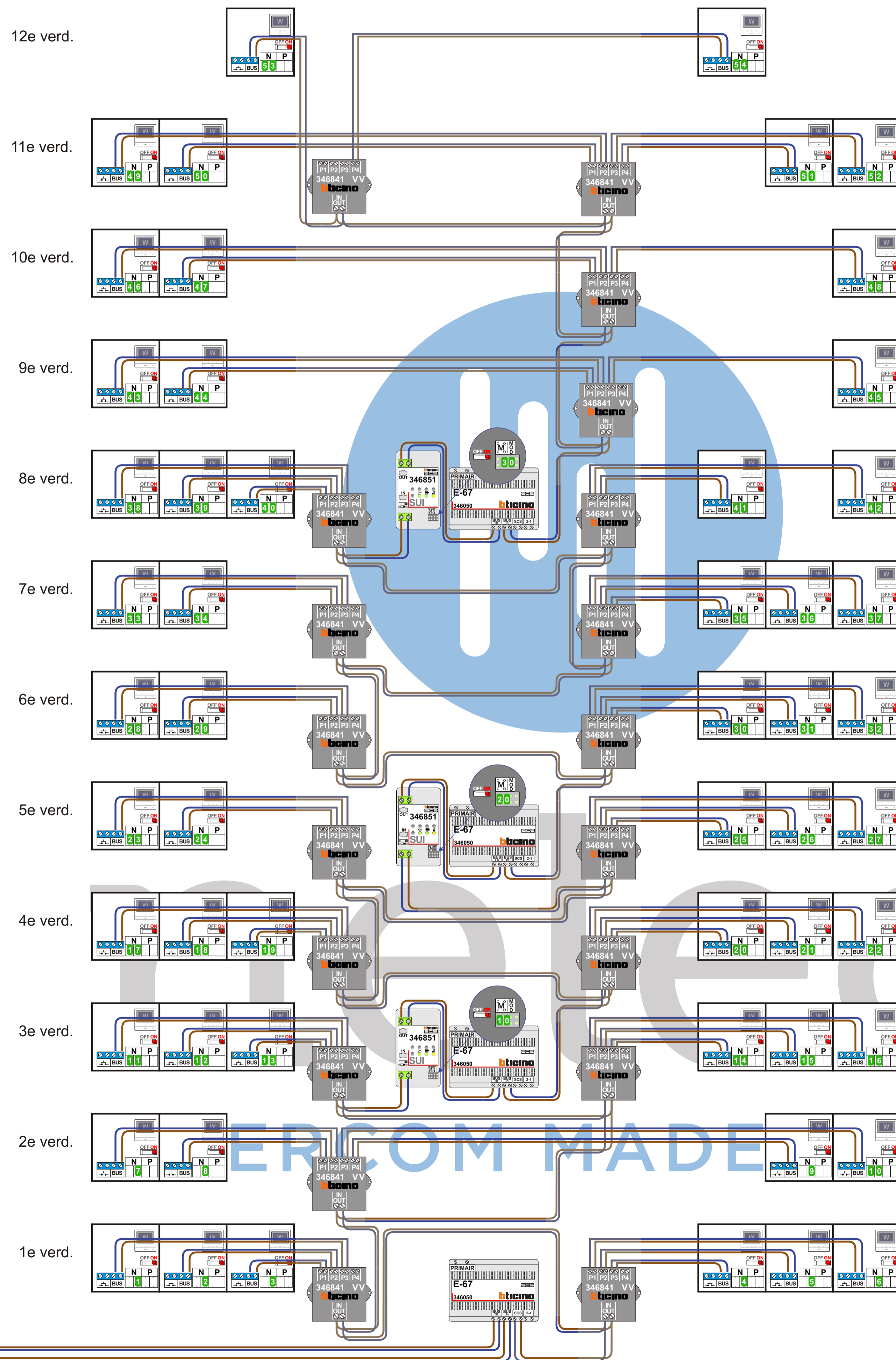

| N-waarde | Huisnummer | Eindweerstand |
|----------|------------|---------------|
| 1 | 151 | X |
| 2 | 152 | X |
| 3 | 153 | X |
| 4 | 154 | X |
| 5 | 155 | X |
| 6 | 156 | X |
| 7 | 157 | X |
| 8 | 158 | X |
| 9 | 159 | X |
| 10 | 160 | X |
| 11 | 161 | X |
| 12 | 162 | X |
| 13 | 163 | X |
| 14 | 164 | X |
| 15 | 165 | X |
| 16 | 166 | X |
| 17 | 167 | X |
| 18 | 168 | X |
| 19 | 169 | X |
| 20 | 170 | X |
| 21 | 171 | X |
| 22 | 172 | X |
| 23 | 173 | X |
| 24 | 174 | X |
| 25 | 175 | X |
| 26 | 176 | X |
| 27 | 177 | X |
| 28 | 178 | X |
| 29 | 179 | X |
| 30 | 180 | X |
| 31 | 181 | X |
| 32 | 182 | X |
| 33 | 183 | X |
| 34 | 184 | X |
| 35 | 185 | X |
| 36 | 186 | X |
| 37 | 187 | X |
| 38 | 188 | X |
| 39 | 189 | X |
| 40 | 190 | X |
| 41 | 191 | X |
| 42 | 192 | X |
| 43 | 193 | X |
| 44 | 194 | X |
| 45 | 195 | X |
| 46 | 196 | X |
| 47 | 197 | X |
| 48 | 198 | X |
| 49 | 199 | X |
| 50 | 200 | X |
| 51 | 201 | X |
| 52 | 202 | X |
| 53 | 203 | X |
| 54 | 204 | X |