

— = systeemkabel  
 Bij andere getwiste kabel **66%** afstand!  
 Bij ongetwiste kabel **max. 50 meter** buitenpost naar videofoon.  
 UTP op aanvraag.

DD8 digitizer: flatcable



Connector van flatcable **nokje juiste kant op** bij aansluiten op DD8

Digitizers & flatcables

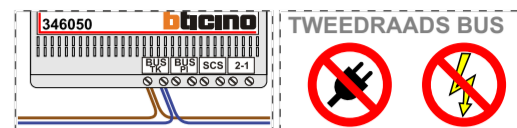

Bij monteren/demonteren **spanning eraf** voorkomt defecten!

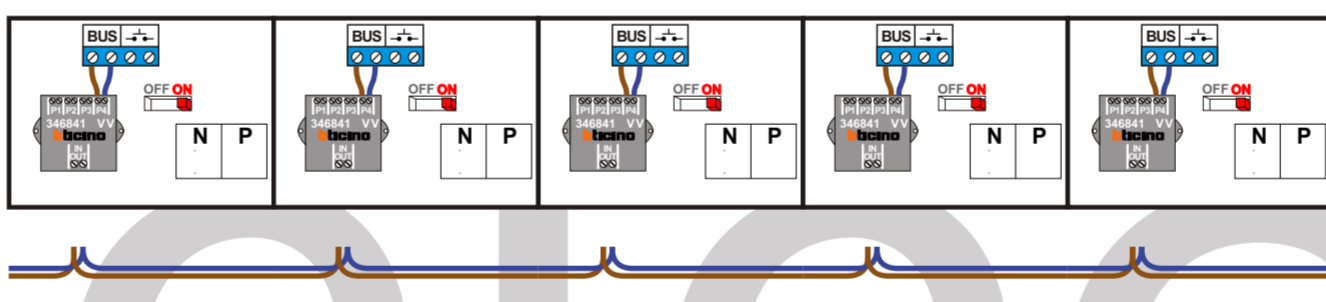
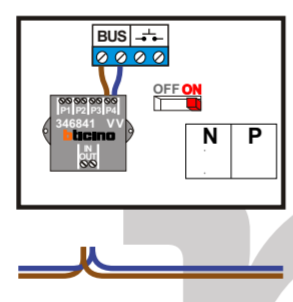
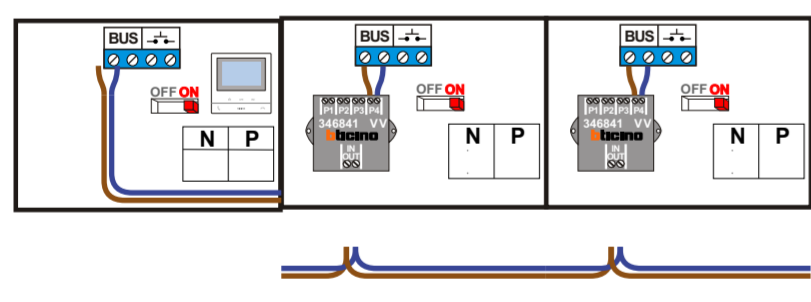
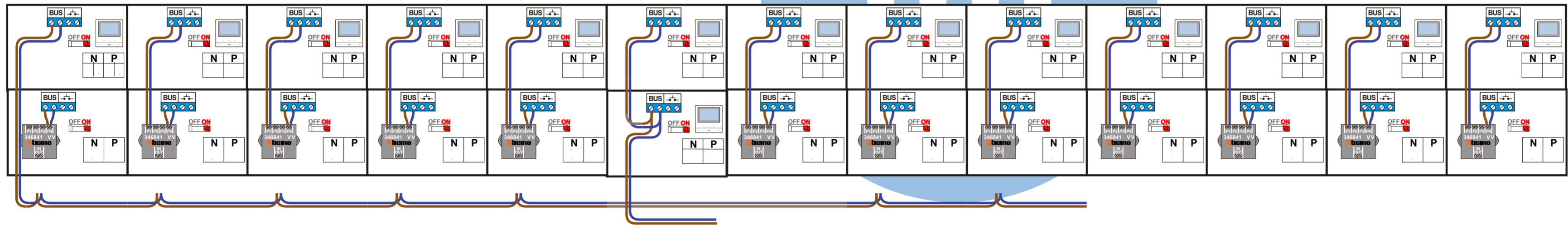
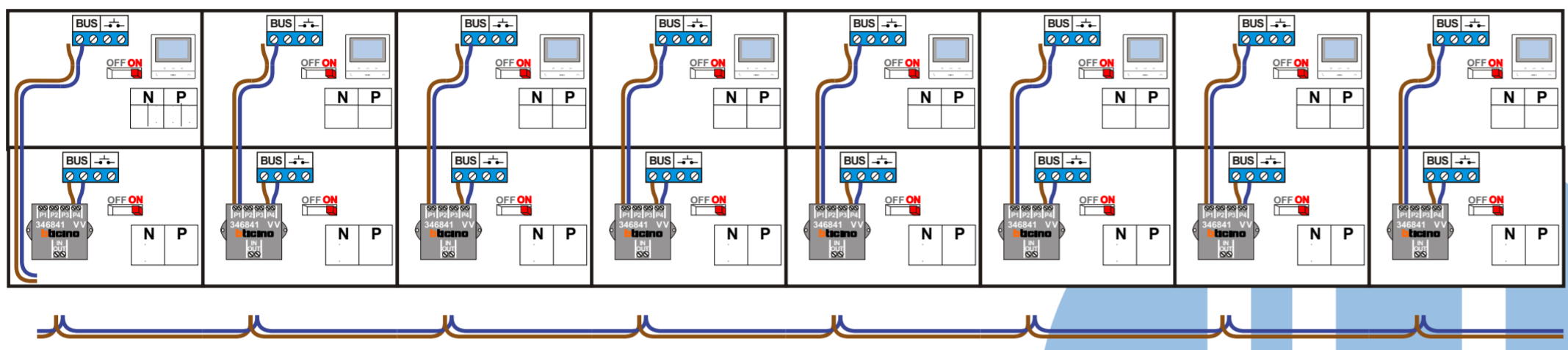

**nelec**

**INTERCOM MADE EASY**

Max. 100 meter systeemkabel tot laatste videofoon

Max. 100 meter systeemkabel tot laatste videofoon

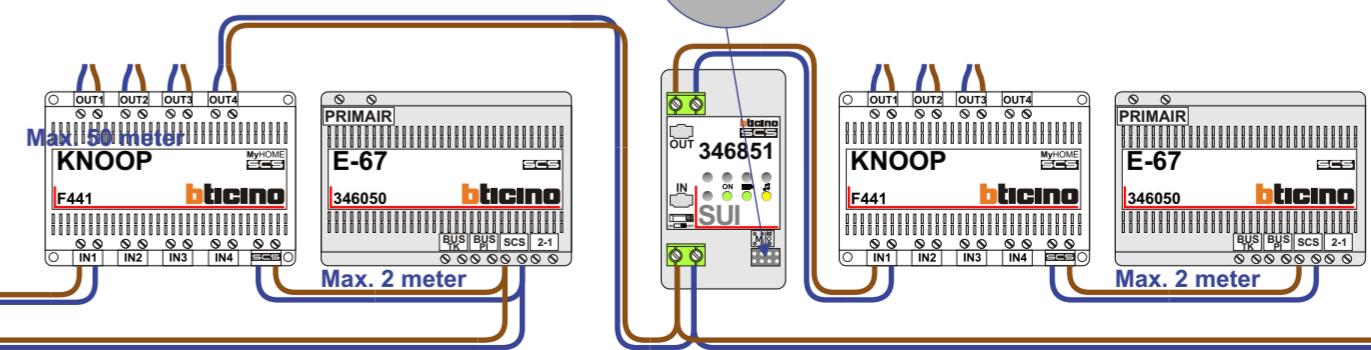

N - w a a r d e	H u i s n u m m e r s	E i n d w e e r s t a n d
1	9	X
2	11	X
3	12	X
4	13	X
5	14	X
6	15	X
7	16	X
8	17	X
9	18	X
10	19	X
11	20	X
12	21	X
13	22	X
14	23	X
15	24	X
16	25	X
17	26	X
18	27	X
19	28	X
20	29	X
21	30	X
22	31	X
23	32	X
24	33	X
25	34	X
26	35	X
27	36	X
28	37	X
29	38	X
30	39	X
31	41	X
32	43	X
33	45	X
34	47	X
35	49	X
36	51	X
37	53	X
38	55	X